



SUMITOMO

CARBIDE - CBN - DIAMOND

WAX Endmill Series



High Performance Milling Systems

High speed, high efficiency shoulder mill for non-ferrous materials

Non-ferrous
Metal



WAX Endmill Series

for shoulder milling of non-ferrous material



Features & Benefits

WAX WaveMill cutters are high speed and high efficiency endmills capable of rough milling to finishing of non-ferrous metals such as Aluminium alloys.

■ Characteristics

- Ideal for ramping (slant milling) and helical milling
- Safety-oriented design prevents dislodging of inserts caused by centrifugal forces
- Coolant holes are a standard feature for the WAX series
- Excellent adhesion resistance
- Top rake face of the insert has a polished finish
- DLC Coat inserts are available for improved adhesion resistance

■ Ramping (Slant Milling)

Maximum ramping angle (α° max.) depends on cutter diameter. Minimum milling length (L min) is the ramping distance required to reach the maximum cutting depth (a_p max) at the maximum ramping angle of that cutter.

Minimum milling length (L) for any depth can be calculated by the equation below:

$$L = \frac{a_p}{\tan \alpha} \quad (\text{mm})$$

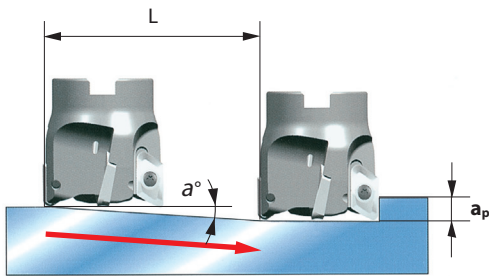

■ Ramping (Slant Milling) Angles

Cutter Diameter ϕD_c (mm/in)	Max. Ramping Angle α° max	
	WAX3000 Type	WAX4000 Type
20/.7874	28°	
25/.9842	17°	26°
32/1.260	12°	18°30'
40/1.575	9°	13°
50/1.969	7°	9°30'
63/2.480	5°	7°
80/3.150	3°	5°
100/3.937	3°	4°
125/4.921	2°	3°

■ Helical Milling

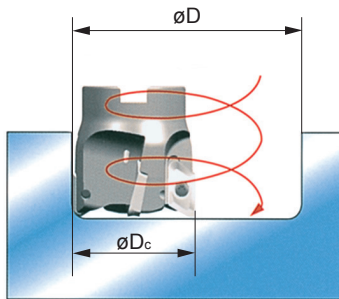

■ Helical Milling Diameter

Cutter Diameter ϕD_c (mm/in)	WAX3000 Type		WAX4000 Type	
	Min. Dia. (mm/in)	Max. Dia. (mm/in)	Min. Dia. (mm/in)	Max. Dia. (mm/in)
20/.7874	19/.7480	33/1.299		
25/.9842	29/1.142	43/1.693	24/.9450	43/1.693
32/1.260	43/1.693	57/2.244	38/1.496	57/2.244
40/1.575	59/2.323	73/2.874	54/2.126	73/2.874
50/1.969	79/3.110	93/3.661	74/2.913	93/3.661
63/2.480	105/4.134	119/4.685	100/3.937	119/4.685
80/3.150	139/5.472	153/6.024	134/5.276	153/6.024
100/3.937	179/7.047	193/7.598	174/6.850	193/7.598
125/4.921	229/9.016	243/9.567	224/8.819	243/9.567

Max. Allowable Spindle Speed

Cutter Diameter ϕD_c (mm/in)	WAX3000 Type		WAX4000 Type	
	n max (min ⁻¹)	v_c (m/min - ft/min)	n max (min ⁻¹)	v_c (m/min - ft/min)
20/.7874	14,000	880/2,887		
25/.9842	29,000	2,200/7,218	11,000	860/2,822
32/1.260	25,000	2,500/8,202	9,000	900/2,953
40/1.575	23,000	2,900/9,514	20,000	2,500/8,202
50/1.969	20,000	3,100/10,171	18,000	2,800/9,186
63/2.480	18,000	3,500/11,483	16,000	3,100/10,171
80/3.150	16,000	4,000/13,123	14,000	3,500/11,483
100/3.937	14,000	4,400/14,436	12,000	3,700/12,139
125/4.921	13,000	5,100/16,732	11,000	4,300/14,108

The n max speeds are set to prevent the inserts from dislodging by centrifugal forces.

Recommended Running Conditions

ISO	Work Material	Hardness	Cutting Speed v_c (m/min) Min. - Optimum - Max.	Feed Rate f_z (mm/t) Min. - Optimum - Max.	Grades
N	Aluminium Alloy	-	600-900-1200	0.05-0.15-0.25	DL1000*/H1

* DLC Coat inserts are available for improved adhesion resistance

WAX 3000 Endmill Cutter Bodies - INCH

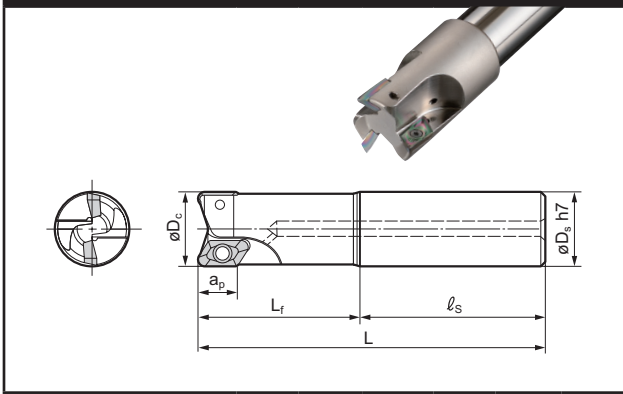

Catalog Number	Dc	Ds	OAL	Lf	ls	No. of teeth
WAX30750EW-3.2	0.750	0.750	4.281	2.000	2.281	1
WAX30750ELC-3.2	0.750	0.750	8.000	2.000	6.000	1
WAX31000EW-3.2	1.000	1.000	4.781	2.500	2.281	2
WAX31000ELC-3.2	1.000	1.000	10.000	2.500	7.500	2
WAX31250EW-3.2	1.250	1.250	4.781	2.500	2.281	2
WAX31250ELC-3.2	1.250	1.250	10.000	2.500	7.500	2
WAX31500EW-3.2	1.500	1.500	4.781	2.500	2.281	3
WAX31500ELC-3.2	1.500	1.500	10.000	2.500	7.500	3
WAX30750EW-4.0	0.750	0.750	4.281	2.000	2.281	1
WAX30750ELC-4.0	0.750	0.750	8.000	2.000	6.000	1
WAX31000EW-4.0	1.000	1.000	4.281	2.000	2.281	2
WAX31000ELC-4.0	1.000	1.000	10.000	2.500	7.500	2
WAX31250EW-4.0	1.250	1.250	4.781	2.500	2.281	2
WAX31250ELC-4.0	1.250	1.250	10.000	2.500	7.500	2
WAX31500EW-4.0	1.500	1.500	4.781	2.500	2.281	3
WAX31500ELC-4.0	1.500	1.500	10.000	2.500	7.500	4

WAX 3000 Shell Mill Cutter Bodies - INCH

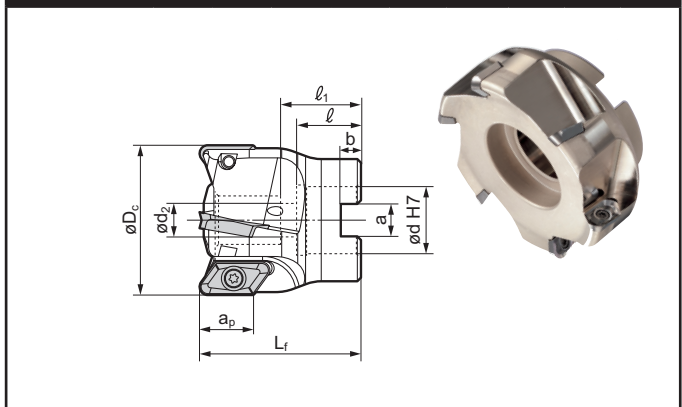

Catalog Number	φDc	Φd	φd2	φd1	L1	a	b	l	No. of teeth
WAX32000-3.2	2.000	0.750	0.406	0.630	1.750	0.312	0.220	0.787	4
WAX32500-3.2	2.500	1.000	0.531	0.630	1.750	0.375	0.220	0.787	5
WAX33000-3.2	3.000	1.000	0.531	1.260	2.000	0.375	0.248	0.866	5
WAX34000-3.2	4.000	1.250	0.656	1.220	2.500	0.500	0.394	1.181	6
WAX35000-3.2	5.000	1.500	0.656	1.220	2.500	0.625	0.394	1.181	7
WAX32000-4.0	2.000	0.750	0.406	0.630	1.750	0.312	0.220	0.787	4
WAX32500-4.0	2.500	1.000	0.531	0.630	1.750	0.375	0.220	0.787	4
WAX33000-4.0	3.000	1.000	0.531	1.260	2.000	0.375	0.248	0.866	5
WAX34000-4.0	4.000	1.250	0.656	1.220	2.500	0.500	0.394	1.181	6
WAX35000-4.0	5.000	1.500	0.656	1.220	2.500	0.625	0.394	1.181	7

All WAX inch size cutters and applicable inserts are USA stocked items.

WAX 4000 Endmill Cutter Bodies - INCH

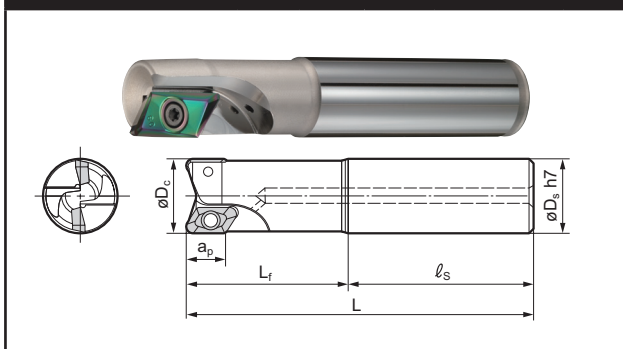

Catalog Number	Dc	Ds	OAL	Lf	ls	No. of teeth
WAX41000EW-3.2	1.000	1.000	4.781	2.500	2.281	1
WAX41000ELC-3.2	1.000	1.000	10.000	2.500	7.500	1
WAX41250EW-3.2	1.250	1.250	4.781	2.500	2.281	1
WAX41250ELC-3.2	1.250	1.250	10.000	2.500	7.500	1
WAX41500EW-3.2	1.500	1.500	4.781	2.500	2.281	2
WAX41500ELC-3.2	1.500	1.500	10.000	2.500	7.500	2
WAX41000EW-4.0	1.000	1.000	4.781	2.500	2.281	1
WAX41000ELC-4.0	1.000	1.000	10.000	2.500	7.500	1
WAX41250EW-4.0	1.250	1.250	4.781	2.500	2.281	1
WAX41250ELC-4.0	1.250	1.250	10.000	2.500	7.500	1
WAX41500EW-4.0	1.500	1.500	4.781	2.500	2.281	2
WAX41500ELC-4.0	1.500	1.500	10.000	2.500	7.500	2

WAX4000 Shell Mill Cutter Bodies - INCH

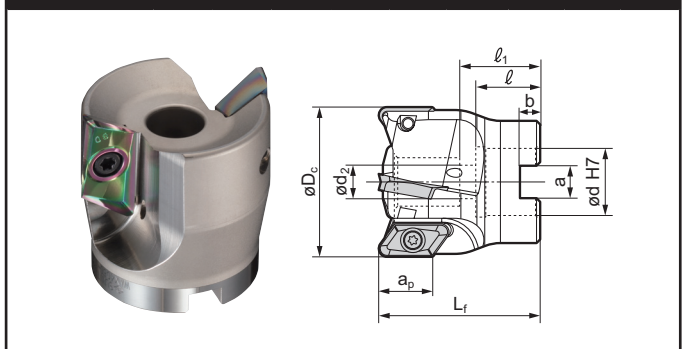

Catalog Number	φDc	Φd	φd2	φd1	L1	a	b	l	No. of teeth
WAX42000-3.2	2.000	0.750	0.406	0.630	2.000	0.312	0.220	0.787	2
WAX42500-3.2	2.500	1.000	0.531	0.630	2.000	0.375	0.220	0.787	3
WAX43000-3.2	3.000	1.000	0.531	1.260	2.000	0.375	0.248	0.866	4
WAX44000-3.2	4.000	1.250	0.656	1.220	2.500	0.500	0.394	1.181	5
WAX45000-3.2	5.000	1.500	0.656	1.220	2.500	0.625	0.394	1.181	6
WAX42000-4.0	2.000	0.750	0.406	0.630	2.000	0.312	0.220	0.787	2
WAX42500-4.0	2.500	1.000	0.531	0.630	2.000	0.375	0.220	0.787	3
WAX43000-4.0	3.000	1.000	0.531	1.260	2.000	0.375	0.248	0.866	4
WAX44000-4.0	4.000	1.250	0.656	1.220	2.500	0.500	0.394	1.181	5
WAX45000-4.0	5.000	1.500	0.656	1.220	2.500	0.625	0.394	1.181	6

All WAX inch size cutters and applicable inserts are USA stocked items.

WAX 3000E/3000EL - METRIC

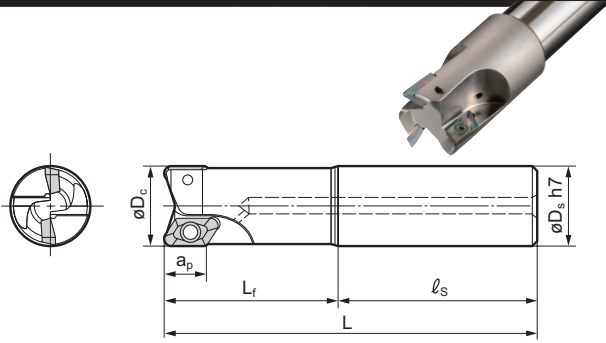

See insert table for "a_p".

Catalog Number	Stock	Dimensions (mm)					No. of Teeth	Weight (kg)
		$\varnothing D_c$	$\varnothing D_s$	L	L_f	ℓ_s		
WAX 3020E-3.2	★	20	20	130	60	70	1	0.25
WAX 3025E-3.2	★	25	25	140	60	80	2	0.42
WAX 3025EL-3.2	★	25	25	200	60	140	2	0.63
WAX 3032E-3.2	★	32	32	150	70	80	2	0.75
WAX 3032EL-3.2	★	32	32	220	70	150	2	1.2
WAX 3040E-3.2	★	40	32	160	70	90	3	1.0
WAX 3040EL-3.2	★	40	32	220	70	150	3	1.4

For inserts with nose radius 3.2mm & below

WAX 3000E/3000EL - METRIC

Catalog Number	Stock	Dimensions (mm)					No. of Teeth	Weight (kg)
		$\varnothing D_c$	$\varnothing D_s$	L	L_f	ℓ_s		
WAX 3020E-4.0	★	20	20	130	60	70	1	0.25
WAX 3025E-4.0	★	25	25	140	60	80	2	0.42
WAX 3025EL-4.0	★	25	25	200	60	140	2	0.63
WAX 3032E-4.0	★	32	32	150	70	80	2	0.75
WAX 3032EL-4.0	★	32	32	220	70	150	2	1.2
WAX 3040E-4.0	★	40	32	160	70	90	3	1.0
WAX 3040EL-4.0	★	40	32	220	70	150	3	1.4

★ = Worldwide Warehouse Item

For inserts with nose radius 4.0mm & larger

WAX 4000E/4000EL - METRIC

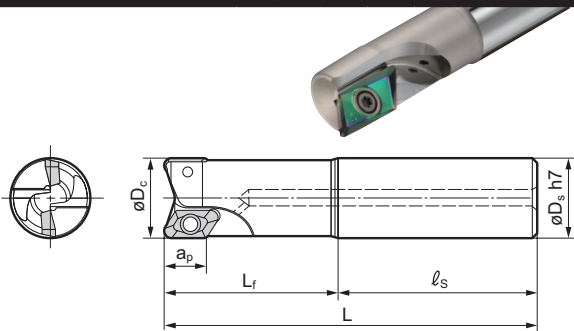

See insert table for "a_p".

Cat. No.	Stock	Dimensions (mm)					No. of Teeth	Weight (kg)
		$\varnothing D_c$	$\varnothing D_s$	L	L_f	ℓ_s		
WAX 4025E-3.2	★	25	25	140	60	80	1	0.41
WAX 4025EL-3.2	★	25	25	200	60	140	1	0.63
WAX 4032E-3.2	★	32	32	150	70	80	1	0.72
WAX 4032EL-3.2	★	32	32	220	70	150	1	1.2
WAX 4040E-3.2	★	40	32	160	70	90	2	0.88
WAX 4040EL-3.2	★	40	32	220	70	150	2	1.2

For inserts with nose radius 3.2mm & below

WAX 4000E/4000EL - METRIC

Cat. No.	Stock	Dimensions (mm)					No. of Teeth	Weight (kg)
		$\varnothing D_c$	$\varnothing D_s$	L	L_f	ℓ_s		
WAX 4025E-4.0	★	25	25	140	60	80	1	0.41
WAX 4025EL-4.0	★	25	25	200	60	140	1	0.63
WAX 4032E-4.0	★	32	32	150	70	80	1	0.72
WAX 4032EL-4.0	★	32	32	220	70	150	1	1.2
WAX 4040E-4.0	★	40	32	160	70	90	2	0.88
WAX 4040EL-4.0	★	40	32	220	70	150	2	1.2

★ = Worldwide Warehouse Item

For inserts with nose radius 4.0mm & larger

WAX 3000 - METRIC

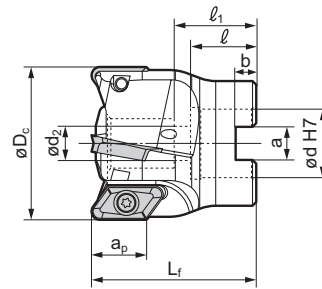

See insert table for "a_p".

Catalog Number	Stock	Dimensions (mm)								No. of Teeth	Weight (kg)
		$\varnothing D_c$	$\varnothing d$	L_f	$\varnothing d_2$	a	b	ℓ	ℓ_1		
WAX 3050-3.2	★	50	22	50	11	10.4	6.3	21	26	4	0.34
WAX 3063-3.2	★	63	22	50	11	10.4	6.3	21	26	5	0.6
WAX 3080-3.2	★	80	25.4	50	14	9.5	6	25	31	5	1.0
WAX 3100-3.2	★	100	31.75	63	17	12.7	8	32	39	6	2.2
WAX 3125-3.2	★	125	38.1	63	21	15.9	10	35	40	7	3.5

For inserts with nose radius 3.2mm & below

WAX 3000 - METRIC

Catalog Number	Stock	Dimensions (mm)								No. of Teeth	Weight (kg)
		$\varnothing D_c$	$\varnothing d$	L_f	$\varnothing d_2$	a	b	ℓ	ℓ_1		
WAX 3050-4.0	★	50	22	50	11	10.4	6.3	21	26	4	0.34
WAX 3063-4.0	★	63	22	50	11	10.4	6.3	21	26	4	0.6
WAX 3080-4.0	★	80	25.4	50	14	9.5	6	25	31	5	1.0
WAX 3100-4.0	★	100	31.75	63	17	12.7	8	32	39	6	2.2
WAX 3125-4.0	★	125	38.1	63	21	15.9	10	35	40	7	3.5

★ = Worldwide Warehouse Item

For inserts with nose radius 4.0mm & larger

WAX 4000 - METRIC

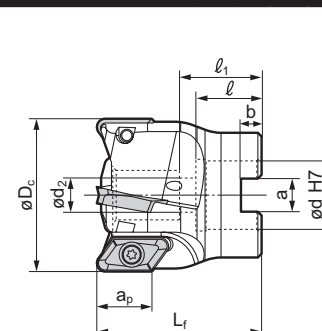

See insert table for "a_p".

Cat. No.	Stock	Dimensions (mm)								No. of Teeth	Weight (kg)
		$\varnothing D_c$	$\varnothing d$	L_f	$\varnothing d_2$	a	b	ℓ	ℓ_1		
WAX 4050-3.2	★	50	16	50	9	8.4	5.6	18	23	2	0.37
WAX 4063-3.2	★	63	22	50	11	10.4	6.3	21	26	3	0.54
WAX 4080-3.2	★	80	25.4	50	14	9.5	6	25	31	4	0.81
WAX 4100-3.2	★	100	31.75	63	17	12.7	8	32	39	5	1.7
WAX 4125-3.2	★	125	38.1	63	21	15.9	10	35	40	6	2.6

For inserts with nose radius 3.2mm & below

WAX 4000 - METRIC

Cat. No.	Stock	Dimensions (mm)								No. of Teeth	Weight (kg)
		$\varnothing D_c$	$\varnothing d$	L_f	$\varnothing d_2$	a	b	ℓ	ℓ_1		
WAX 4050-4.0	★	50	16	50	9	8.4	5.6	18	23	2	0.37
WAX 4063-4.0	★	63	22	50	11	10.4	6.3	21	26	3	0.54
WAX 4080-4.0	★	80	25.4	50	14	9.5	6	25	31	4	0.81
WAX 4100-4.0	★	100	31.75	63	17	12.7	8	32	39	5	1.7
WAX 4125-4.0	★	125	38.1	63	21	15.9	10	35	40	6	2.6

★ = Worldwide Warehouse Item

For inserts with nose radius 4.0mm & larger

Inserts for all WAX 3000 Endmills

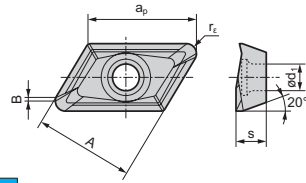

● = USA Stocked Item

Catalog Number	Carbide		Dimensions - In. (mm)					
	HI	DL1000	ap	A	B	re	s	ød1
			DLC					
AECT 160404PEFRA	●	●	0.708 (18)	0.6456 (16.4)	0.055 (1.4)	0.016 (0.4)	0.1968 (5)	0.1732 (4.4)
AECT 160408PEFRA	●	●	0.708 (18)	0.6456 (16.4)	0.039 (1.0)	0.031 (0.8)	0.1968 (5)	0.1732 (4.4)
AECT 160412PEFRA	●	●	0.708 (18)	0.6456 (16.4)	0.023 (0.6)	0.047 (1.2)	0.1968 (5)	0.1732 (4.4)
AECT 160416PEFRA	●	●	0.689 (17.5)	0.6456 (16.4)	0.020 (0.5)	0.063 (1.6)	0.1968 (5)	0.1732 (4.4)
AECT 160420PEFRA	●	●	0.689 (17.5)	0.6456 (16.4)	0.020 (0.5)	0.079 (2.0)	0.1968 (5)	0.1732 (4.4)
AECT 160430PEFRA	●	●	0.669 (17)	0.6456 (16.4)	0.028 (0.7)	0.118 (3.0)	0.1968 (5)	0.1732 (4.4)
AECT 160432PEFRA	●	●	0.669 (17)	0.6456 (16.4)	0.020 (0.5)	0.126 (3.2)	0.1968 (5)	0.1732 (4.4)
AECT 160440PEFRA	●	●	16.5	0.6456 (16.4)	0.020 (0.5)	0.157 (4.0)	0.1968 (5)	0.1732 (4.4)
AECT 160450PEFRA	●	●	0.630 (16)	0.6456 (16.4)	0.016 (0.4)	0.197 (5.0)	0.1968 (5)	0.1732 (4.4)

re = 4.0 or greater are for use with bodies that have a -4.0 catalog number suffix.

Hardware for all WAX 3000 Endmills

Screw	Spanner	Anti-seizure Paste	Recommended Tightening Torque (N-m)	Applicable Endmill
			3.0	WAX3000 WAX3000E/EL
BFTX0408	TRD15	SUMI-P		

Inserts for all WAX 4000 Endmills

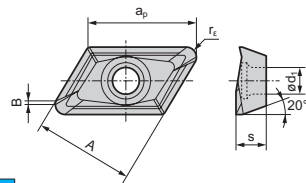

● = USA Stocked Item

Catalog Number	Carbide		Dimensions - In. (mm)					
	HI	DL1000	ap	A	B	re	s	ød1
			DLC					
AECT 220604PEFRA	●	●	0.945 (24)	0.8563 (21.8)	0.059 (1.5)	0.016 (0.4)	0.250 (6.35)	0.236 (6.0)
AECT 220608PEFRA	●	●	0.945 (24)	0.8563 (21.8)	0.047 (1.2)	0.031 (0.8)	0.250 (6.35)	0.236 (6.0)
AECT 220612PEFRA	●	●	0.945 (24)	0.8563 (21.8)	0.031 (0.8)	0.047 (1.2)	0.250 (6.35)	0.236 (6.0)
AECT 220616PEFRA	●	●	0.945 (24)	0.8563 (21.8)	0.016 (0.4)	0.063 (1.6)	0.250 (6.35)	0.236 (6.0)
AECT 220620PEFRA	●	●	0.945 (24)	0.8563 (21.8)	0.020 (0.5)	0.079 (2.0)	0.250 (6.35)	0.236 (6.0)
AECT 220630PEFRA	●	●	0.905 (23)	0.8563 (21.8)	0.023 (0.6)	0.118 (3.0)	0.250 (6.35)	0.236 (6.0)
AECT 220632PEFRA	●	●	0.905 (23)	0.8563 (21.8)	0.016 (0.4)	0.126 (3.2)	0.250 (6.35)	0.236 (6.0)
AECT 220640PEFRA	●	●	0.866 (22)	0.8563 (21.8)	0.047 (1.2)	0.157 (4.0)	0.250 (6.35)	0.236 (6.0)
AECT 220650PEFRA	●	●	0.866 (22)	0.8563 (21.8)	0.016 (0.4)	0.197 (5.0)	0.250 (6.35)	0.236 (6.0)

re = 4.0 or greater are for use with bodies that have a -4.0 catalog number suffix.

Hardware for all WAX 4000 Endmills

Screw	Spanner	Anti-seizure Paste	Recommended Tightening Torque (N-m)	Applicable Endmill
			5.0	ø25 to ø32
BFTX0509N	TRD20	SUMI-P		
BFTX0511N	TRD20	SUMI-P		ø40 to ø125



星隆貿易股份有限公司
Sing-Lung Trading Co., Ltd.

專業 | 誠信 | 品質 | 服務



TEL: 02-25955260 FAX: 02-25944938



ADD: 台北市大同區承德路三段67號



E-mail: sales@sl.com.tw



WEB: www.sl.com.tw